

INDEX OF SHEETS
SEE SHEET IL1

CITY OF WALTERBORO

PROPOSED PLANS FOR

COLLETON COUNTY
SC 63 (SOUTH JEFFERIES BLVD)
FROM: ELIZABETH STREET (S-15-125)
TO: BENSON ST (S-15-293)

Hydraulic Design Reference for these plans is the:
2009
Edition of SCDOT's "Requirements for Hydraulic Design Studies"

Design Reference for these plans is the:
2001
AASHTO "A Policy on Geometric Design of Highways and Streets"

NPDES PERMIT INFORMATION

Disturbed Area = 0.00 Acre(s)
Project Area = 2.80 Acre(s)

Approximate Location of Roadway is

Begin
Latitude 32° 53' 56.62"N
Longitude 80° 40' 8.03"W

End
Latitude 32° 54' 14.74"N
Longitude 80° 40' 1.36"W

PROJ. NO. 31588.00
SC 63
SURVEY STA. 5+80.00 TO STA. 7+55.00
SEE SHEETS 6-8



LAYOUT
SCALE 1 INCH = 1250 FEET

ENVIRONMENTAL PERMIT INFORMATION			
USACE PERMIT	<input type="checkbox"/> YES	<input checked="" type="checkbox"/> NO	
NEPA DOCUMENT	<input type="checkbox"/> YES	<input checked="" type="checkbox"/> NO	
401 CERTIFICATION	<input type="checkbox"/> YES	<input checked="" type="checkbox"/> NO	
OCRM CAP	<input type="checkbox"/> YES	<input checked="" type="checkbox"/> NO	
NAVIGABLE WATERS	<input type="checkbox"/> SC	<input type="checkbox"/> USCG	<input type="checkbox"/> USACE <input checked="" type="checkbox"/> N/A

3 DAYS BEFORE DIGGING IN
SOUTH CAROLINA
CALL 811
SOUTH CAROLINA 811 (SC811)
WWW.SC811.COM
ALL UTILITIES MAY NOT BE A MEMBER OF SC811

RAILROAD INVOLVEMENT?
YES NO

TRAFFIC DATA		
2017	ADT	14,300
2037	ADT	15,879
	TRUCKS	10 %

NET LENGTH OF ROADWAY	0.374	MILES
NET LENGTH OF BRIDGES	0.000	MILES
NET LENGTH OF PROJECT	0.374	MILES
LENGTH OF EXCEPTIONS	0.000	MILES
GROSS LENGTH OF PROJECT	0.374	MILES

EQUALITIES IN STATIONING
NONE

NOTE: EXCEPT AS MAY OTHERWISE BE SPECIFIED ON THE PLANS OR IN THE SPECIAL PROVISIONS, ALL MATERIALS AND WORKMANSHIP ON THIS PROJECT SHALL CONFORM TO THE SOUTH CAROLINA DEPARTMENT OF TRANSPORTATION STANDARD SPECIFICATIONS FOR HIGHWAY CONSTRUCTION (2007 EDITION) AND THE STANDARD DRAWINGS FOR ROAD CONSTRUCTION IN EFFECT AT THE TIME OF LETTING.

CONSULTING ENGINEERING FIRM
DAVIS & FLOYD
SINCE 1954
WWW.DAVISFLOYD.COM

SCDOT REVIEW	RIGHT-OF-WAY		CONSTRUCTION	
	INITIAL	DATE	INITIAL	DATE
PRECONSTRUCTION SUPPORT - ROAD				
PRECONSTRUCTION SUPPORT - STRUCTURES				
RPG - DESIGN MANAGER				
RPG - PROGRAM MANAGER				

THE INITIALS ABOVE DO NOT RELIEVE THE ENGINEER OF RECORD OF THE RESPONSIBILITY TO DESIGN THIS PROJECT IN ACCORDANCE WITH ALL APPLICABLE CRITERIA.

ENGINEER OF RECORD

DAVIS & FLOYD, INC.
No. C00538

REGISTERED PROFESSIONAL ENGINEER
No. 20214
GEORGE TILLEY RALL

FOR CONSTRUCTION: [Signature] 08/03/18
DATE

SUMMARY OF ESTIMATED QUANTITIES

FED. RD. DIV. NO.	STATE	COUNTY	PROJECT NO.	ROUTE NO.	SHEET NO.	TOTAL SHEETS
3	S.C.	COLLETON	31588.00	SC 63	2	

ITEM NO.	DESCRIPTION	UNIT	QUANTITY
1031000	MOBILIZATION	LS	NEC
1032010	BONDS AND INSURANCE	LS	1.000
1050800	CONSTRUCTION STAKES, LINES & GRADES	EA	1.000
1071000	TRAFFIC CONTROL	LS	NEC
1080300	CPM PROGRESS SCHEDULE	LS	NEC
1090200	AS-BUILT CONSTRUCTION PLANS	LS	1.000
4011004	LIQUID ASPHALT BINDER PG64-22	TON	70.000
4012080	FULL DEPTH ASPH. PAV. PATCHING 8" UNIF	SY	100.000
4013990	MILLING EXISTING ASPHALT PAVEMENT (VARIABLE)	SY	13,550.000
4030320	HOT MIX ASPHALT SURFACE COURSE TYPE B	TON	1,225.000
4039013	ASPHALT PAVEMENT TEXTURING - HERRINGBONE(BRICK)	SY	585.000
6051120	PERMANENT CONSTRUCTION SIGNS (GROUND MOUNTED)	SF	392.000
6250005	4" WHITE BROKEN LINES -(GAPS EXCLUDED)-FAST DRY PAINT	LF	2,356.000
6250010	4" WHITE SOLID LINES (PVT. EDGE LINES)-FAST DRY PAINT	LF	520.000
6250015	8"WHITE SOLID LINES(CROSSWALK&CHANNELIZATION)FAST DRY PAINT	LF	1,720.000
6250020	12" WHITE SOLID LINES - FAST DRY PAINT	LF	300.000
6250025	24" WHITE SOLID LINES (STOP/DIAGONAL LINES)-FAST DRY PAINT	LF	410.000
6250030	WHITE SINGLE ARROW (LEFT, STRAIGHT, RIGHT)-FAST DRY PAINT	EA	18.000
6250035	WHITE WORD MESSAGE "ONLY"-FAST DRY PAINT	EA	14.000
6250110	4"YELLOW SOLID LINE(PVT EDGE&NO PASSING ZONE)-FAST DRY PAINT	LF	8,660.000
6250112	6" YELLOW SOLID LINE ON CURB/MEDIAN - FAST DRY PAINT	LF	1,100.000
6271005	4" WHITE BROKEN LINES(GAPS EXCL.)THERMOPLASTIC- 90 MIL.	LF	1,178.000
6271010	4" WHITE SOLID LINES (PVT. EDGE LINES) THERMO.- 90 MIL.	LF	260.000
6271015	8" WHITE SOLID LINES THERMOPLASTIC - 125 MIL.	LF	860.000
6271020	12" WHITE SOLID LINES - THERMO. - 125 MIL.	LF	150.000
6271025	24" WHITE SOLID LINES (STOP/DIAG LINES)-THERMO.-125 MIL	LF	205.000
6271030	WHITE SINGLE ARROWS (LT, STRGHT, RT) THERMO.-125 MIL.	EA	9.000
6271035	WHITE WORD MESSAGE "ONLY" -THERMOPLASTIC - 125 MIL.	EA	7.000
6271074	4" YELLOW SOLID LINES(PVT.EDGE LINES) THERMO-90 MIL.	LF	4,330.000
6280112	6"YELLOW SOLID LINES ON CURB/MED.-HIGH BUILD PAINT-25 MIL.	LF	1,100.000
6300005	PERMANENT CLEAR PAVEMENT MARKERS- MONO-DIR.- 4"X4"	EA	70.000
6301100	PERMANENT YELLOW PAVEMENT MARKERS BI-DIR.- 4"X4"	EA	130.000
6510105	FLAT SHEET, TYPE III, FIXED SZ. & MSG. SIGN	SF	20.000
6531210	U-SECTION POST FOR SIGN SUPPORTS - 3P	LF	42.000
6750275	FURNISH & INSTALL 1.0" SCHEDULE 80 PVC CONDUIT	LF	65.000
6770413	FURNISH & INSTL NO. 14 COPPER WIRE,1-CONDUCTOR FOR LOOP WIRE	LF	3,185.000
6780495	SAWCUT FOR LOOP DETECTOR	LF	1,295.000
6885992	TEMPORARY ADJUSTMENT OF TRAFFIC SIGNAL EQUIPMENT	LS	1.000
S000001	CONCRETE MEDIAN WITH TEXTURING - HERRINGBONE(BRICK)	SY	250.000

DAVIS & FLOYD
SINCE 1954

WWW.DAVISFLOYD.COM

3229 W. MONTAGUE AVENUE
COLUMBIA, SC 29204
(803) 733-2888

This drawing copy may have been reproduced at a size different than the original drawing. No responsibility is assumed for the use of incorrect scale. Drawings are not to be scaled.



PREPARED FOR:
I-95 BUSINESS LOOP PHASE 1E
SUMMARY OF ESTIMATED QUANTITIES
Walterboro, South Carolina

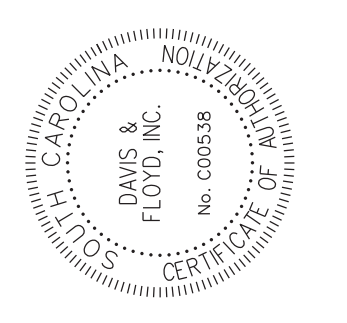
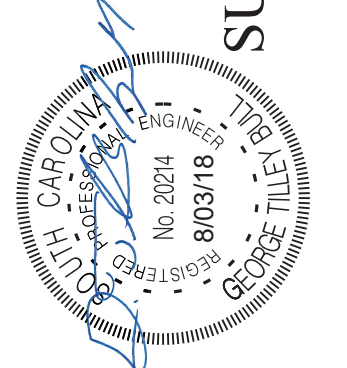

DGN: LEK
R/W: GBT
CHK: GBT

#	REVISION	DATE	BY
1	UPDATE QUANTITIES	05/28/15	AMS

SHEET NUMBER
2

TYPICAL SECTION

FED. RD. DIV. NO.	STATE	COUNTY	PROJECT NO.	ROUTE NO.	SHEET NO.	TOTAL SHEETS
3	S.C.	COLLETON	31588.00	SC 63	3	

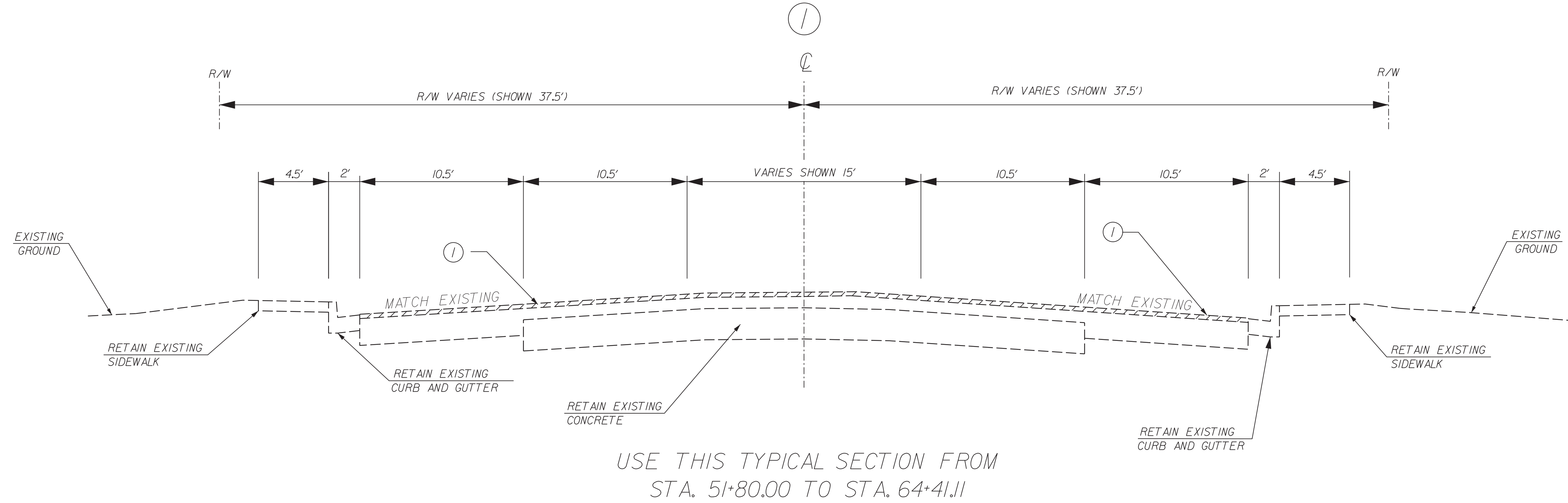

* NOTE:
PRIOR TO INSTALLATION OF MEDIAN, VARIABLE MILL AND RESURFACE TO SHIFT CROWN OF ROAD TO EDGE OF RAISED CONCRETE MEDIAN TO PROVIDE POSITIVE DRAINAGE

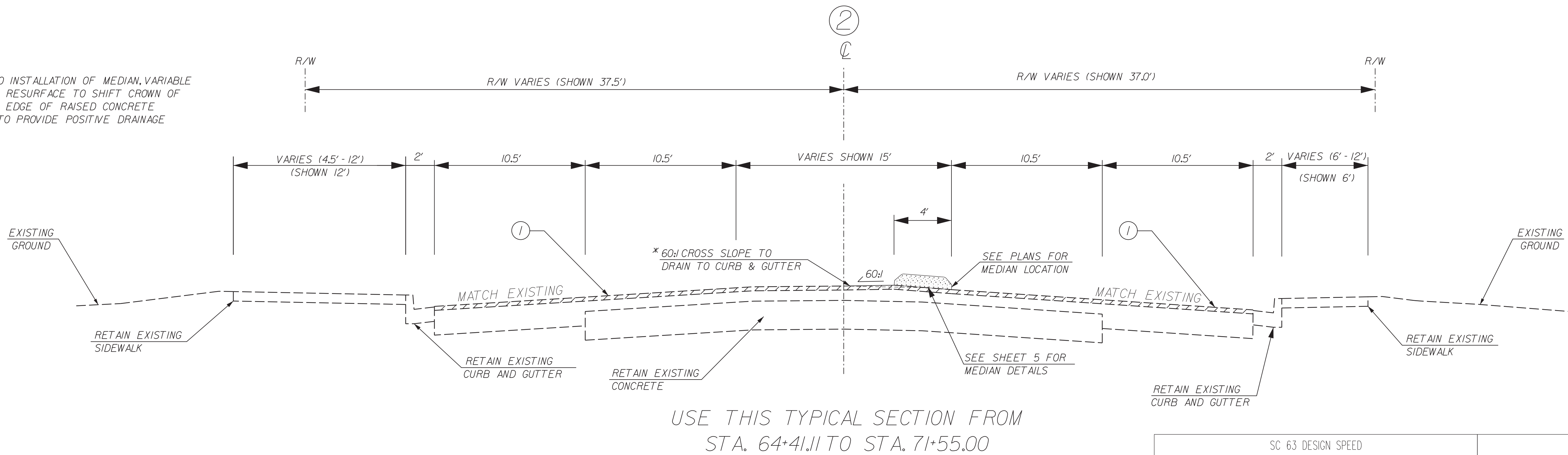

PAVEMENT LEGEND	
(1) [Hatched Box]	VARIABLE MILL AND RESURFACE WITH 175*SY ASPHALT SURFACE COURSE TYPE B

SC 63 DESIGN SPEED		
MPH	FROM STA.	TO STA.
35	51+80	71+55
EXCEPTIONS TO DESIGN SPEED		

ROAD FUNCTIONAL CLASSIFICATION FOR THIS ROUTE IS URBAN MINOR ARTERIAL

REVISION	BY	DATE
#		

DAVIS & FLOYD
SINCE 1954

3229 W. MONTAGUE AVENUE
COLUMBIA, SC 29205
803.752.2400

This drawing copy may have been reproduced at a size different than the original drawing. No responsibility is assumed for the use of incorrect scale. Drawings are not to be scaled.



SCALE: 1"=2' SCALE 1"=4'

SHEET NUMBER
3

12:16:32 PM FILE NAME: \CHS-FSD\Drawings\Even\31588-00\CV_dgn\1001-Phase 1E (BITI)-local\3158800-IBIT-03-typical-1B.dgn PLOTTED: 8/3/2018



PREPARED FOR:
I-95 BUSINESS LOOP PHASE 1E TYPICAL SHEET
Walterboro, South Carolina

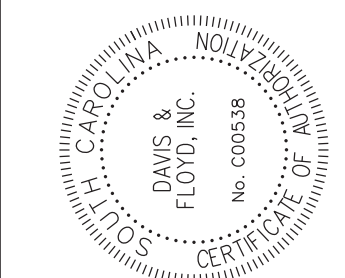
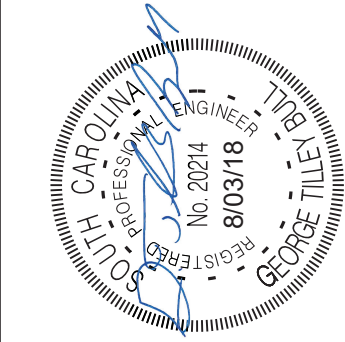

DGN: LEK
R/W: GTB
CHK: GTB

FED. RD. DIV. NO.	STATE	COUNTY	PROJECT NO.	ROUTE NO.	SHEET NO.	TOTAL SHEETS
3	S.C.	COLLETON	31588.00	SC 63	5	

SOUTH JEFFERIES BLVD

GENERAL CONSTRUCTION NOTES:

THE CONTRACTOR MUST PERFORM ALL WORK IN ACCORDANCE WITH THE SOUTH CAROLINA DEPARTMENT OF TRANSPORTATION STANDARD DRAWINGS FOR ROAD CONSTRUCTION (LATEST EDITION), SCDOT STANDARD SPECIFICATIONS FOR HIGHWAY CONSTRUCTION (LATEST EDITION), SCDOT TRAFFIC SIGNAL SPECIFICATIONS, THE MUTCD, 2009 EDITION, AND THE REVISED DRAFT GUIDELINES FOR PUBLIC RIGHT-OF-WAY (PROWAG) 2005 OF THE U.S. ACCESS BOARD.

THE LOCATIONS OF EXISTING UTILITIES AND STORM DRAINAGE FACILITIES SHOWN ON THE PLANS ARE PROVIDED FOR THE CONVENIENCE OF THE CONTRACTOR. THE ENGINEER ASSUMES NO RESPONSIBILITY FOR THE ACCURACY OR COMPLETENESS OF THE UTILITIES INFORMATION SHOWN ON THE DRAWINGS. IT IS THE CONTRACTOR'S RESPONSIBILITY TO VERIFY THE EXACT LOCATION OF ALL UTILITIES BEFORE CONSTRUCTION. PRIOR TO THE START OF ANY CONSTRUCTION ACTIVITY, IT SHALL BE THE CONTRACTOR'S RESPONSIBILITY TO CONFIRM THAT THE PROPER COORDINATION WITH THE VARIOUS UTILITY OWNERS HAS BEEN PERFORMED. THE CONTRACTOR SHALL COOPERATE WITH THE UTILITY DURING RELOCATION OPERATIONS.

THE LOCATION OF UTILITIES SHOWN IN THE PLANS SHOULD BE CONSIDERED APPROXIMATE ONLY. THE VERIFIED LOCATIONS/ELEVATIONS APPLY ONLY AT THE POINTS DESIGNATED BY A TEST HOLE. INTERPOLATIONS BETWEEN THESE POINTS HAVE NOT BEEN VERIFIED.

THE CONTRACTOR SHALL PROTECT ALL EXISTING STRUCTURES, STORM DRAINS, UTILITIES AND OTHER FACILITIES TO REMAIN AND SHALL REPAIR ANY DAMAGES DUE TO CONSTRUCTION ACTIVITIES AT NO ADDITIONAL COST TO THE OWNER.

THE CONTRACTOR SHALL NOT STORE ANY MATERIALS OR EQUIPMENT WITHIN 15 FT OF THE EDGE OF TRAVEL WAY.

PIPE LENGTHS THAT ARE SHOWN ON THE PLANS ARE CALCULATED ALONG THE PIPE SLOPE FROM CENTER OF BOX TO CENTER OF BOX. FIELD ADJUSTMENTS OF THE ACTUAL PIPE LENGTHS MAY BE NECESSARY.

FINAL SURFACE COURSE ON ALL ROADWAYS SHALL NOT BE PLACED UNTIL ALL DRAINAGE AND CURB AND GUTTER INSTALLATIONS ARE COMPLETE.

THE CONTRACTOR SHALL PROVIDE AND MAINTAIN PROPER DEWATERING PROCEDURES TO PREVENT THE FLOW AND ACCUMULATION OF SURFACE AND GROUND WATER IN EXCAVATED AREAS. ALL OF THE WATER PUMPED OR DRAINED SHALL BE DISPOSED OF WITHOUT UNDUE INTERFERENCE WITH OTHER WORK OR DAMAGE TO PAVEMENTS AND OTHER SURFACES OR PROPERTY. DISCHARGED WATER FROM ALL DEWATERING OPERATIONS SHALL BE FILTERED IN ACCORDANCE WITH SCDHEC REGULATIONS OR AS APPROVED BY THE ENGINEER.

THE CONTRACTOR SHALL PROVIDE A DETAILED TRAFFIC CONTROL PLAN TO THE RESIDENT CONSTRUCTION MANAGER FOR APPROVAL BEFORE STARTING ANY WORK ON THE PROJECT. THIS PLAN SHALL INCLUDE DETAILS CONCERNING PLACEMENT OF REFLECTORIZED BARRELS, CONES, AND/OR TYPE 2 BARRICADES IN ACCORDANCE WITH THE 2009 MUTCD.

THE CONTRACTOR SHALL PRESERVE AND PROTECT FROM INJURY ALL TREES NOT INDICATED TO BE REMOVED. PRUNE AND PAINT ALL TREES DAMAGED IN A SATISFACTORY MANNER AS APPROVED BY THE ENGINEER. REASONABLE CARE SHALL BE TAKEN DURING CONSTRUCTION TO AVOID DAMAGE TO VEGETATION. ORNAMENTAL SHRUBBERY AND TREE BRANCHES SHALL BE TIED BACK, WHERE APPROPRIATE, TO MINIMIZE DAMAGE. TREES WHICH RECEIVE DAMAGE TO BRANCHES SHALL BE TRIMMED OF THOSE BRANCHES TO IMPROVE THE APPEARANCE OF THE TREE. TREE TRUNKS RECEIVING DAMAGE FROM EQUIPMENT SHALL BE TREATED WITH A TREE DRESSING. ALL TREE DRESSING AND REPAIRS SHALL BE PERFORMED BY OR UNDER THE DIRECT SUPERVISION OF A TREE ARBORIST.

THE CONTRACTOR SHALL PROVIDE ALL SHEETING, SHORING, AND BRACING REQUIRED TO PROTECT ADJACENT STRUCTURES AND UTILITIES OR TO MINIMIZE TRENCH WIDTH AS REQUIRED. PAYMENT FOR SUCH MEASURES IS INCLUDED IN THE BID PRICE FOR THE ITEM BEING CONSTRUCTED.

WHERE STORM PIPES AND STRUCTURES ARE IDENTIFIED TO BE ABANDONED IN PLACE, THE FOLLOWING PROCEDURES SHALL BE UTILIZED:

- PIPES: PLUG END(S) WITH BRICK AND GROUT.
- STRUCTURES: REMOVE RIM/COVER AND CONE OR TOP SLAB.
- PLUG PIPE OPENINGS WITH BRICK AND GROUT.
- FILL STRUCTURE WITH FLOWABLE FILL TO BOTTOM OF PAVEMENT SECTION.
- TEMPORARY ASPHALT IF NEEDED.

THE CONTRACTOR SHALL REVIEW AND VERIFY ALL DIMENSIONS SHOWN ON THE PLANS AND REVIEW ALL FIELD CONDITIONS THAT MAY AFFECT CONSTRUCTION. SHOULD DISCREPANCIES OCCUR, THE CONTRACTOR SHALL NOTIFY THE ENGINEER TO OBTAIN THE ENGINEER'S CLARIFICATION BEFORE COMMENCING CONSTRUCTION.

THE ENGINEER RESERVES THE RIGHT TO ADJUST THE LOCATION OF ALL PROPOSED IMPROVEMENTS TO MEET FIELD CONDITIONS IF NECESSARY.

TRAFFIC MAY NOT RIDE ON A MILLED SURFACE FOR MORE THAN 5 CALENDAR DAYS.

THE FOLLOWING QUANTITIES ARE NOT SHOWN IN DETAIL ON THE PLANS BUT ARE INCLUDED IN THE SUMMARY OF ESTIMATED QUANTITIES AND MAY BE ADJUSTED DURING CONSTRUCTION AS DIRECTED BY THE ENGINEER.

INCLUSION ITEMS

INCLUSION ITEMS			
DESCRIPTION	UNIT	QUANTITY	DESCRIPTION
MOBILIZATION	LS	NEC	PER CONTRACT DOCUMENTS
BONDS AND INSURANCE	LS	1	PER CONTRACT DOCUMENTS
CONSTRUCTION STAKES, LINES & GRADES	EA	1	PER CONTRACT DOCUMENTS
CPM PROGRESS SCHEDULE	LS	NEC	PER CONTRACT DOCUMENTS
FULL DEPTH ASPH. PAV. PATCHING 8" UNIF	SY	100	WHERE DIRECTED BY ENGINEER
FURNISH & INSTALL 1.0" SCHEDULE 80 PVC CONDUIT	LF	65	WHERE DIRECTED BY ENGINEER
FURNISH & INSTL NO. 14 COPPER WIRE, 1-CONDUCTOR FOR LOOP WIRE	LF	3185	WHERE DIRECTED BY ENGINEER
SAWCUT FOR LOOP DETECTOR	LF	1295	WHERE DIRECTED BY ENGINEER
TEMPORARY ADJUSTMENT OF TRAFFIC SIGNAL EQUIPMENT	LS	1	WHERE DIRECTED BY ENGINEER

SCDOT STANDARD DRAWING DETAILS

- SEE SCDOT STANDARD DRAWING NO. 605-010-02 FOR PERMANENT CONSTRUCTION SIGNS DETAILS.
- SEE SCDOT STANDARD DRAWING NO. 625-305-00 AND 625-410-00 FOR PAVEMENT MARKING DETAILS.
- SEE SCDOT STANDARD DRAWING NO. 630-105-00, 630-205-00, 630-210-00 AND 630-215-00 FOR RAISED PAVEMENT MARKER DETAILS.
- SEE SCDOT STANDARD DRAWING NO. 675-110-00, 675-120-00, AND 675-130-01 FOR LOOP DETECTION DETAILS.
- SEE SCDOT STANDARD DRAWING NO. 720-105-03 FOR CONCRETE MEDIAN DETAILS.

4' RAISED CONCRETE MEDIAN NOTES:

- SEE PLAN SHEETS FOR CONCRETE MEDIAN LOCATIONS.
- INSTALL MEDIAN AFTER SURFACE HAS BEEN MILLED AND REPAVED.
- USE MINIMUM SCDOT CLASS 3000 CONCRETE.
- USE (2) 1/2" DIAMETER STEEL DOWELS WITH 10 1/2" EMBEDMENT INTO PAVEMENT AT 10 FOOT INTERVALS.
- CONCRETE TEXTURING PATTERN SHALL BE HERRINGBONE BRICK (SIENNA COLOR PER ASTM C 979).
- CONTRACTOR SHALL SUBMIT COLOR AND PATTERN FOR CITY APPROVAL PRIOR TO INSTALLATION.
- CONTRACTOR SHALL SUBMIT PLANS FOR STAMPING AND COLORING CONCRETE.
- MEDIAN AND TEXTURING SHALL BE PAID FOR AS CONCRETE MEDIAN WITH TEXTURING - HERRINGBONE BRICK.

FILE NAME: \CHS-FS\Drawn\Jobs\Even\31588-00\Cv_dgn\civ\civ-Phase 1E (1)11-10a01.3158800-1B11-05-gcd.dgn
 11:24:40 AM
 PLOTTED: 8/17/2018

PREPARED FOR:



CITY OF WALTERBORO
102 W. WALTON STREET
WALTERBORO, SOUTH CAROLINA 29488

**I-95 BUSINESS LOOP
 PHASE 1E
 GENERAL CONSTRUCTION NOTES**

Walterboro, South Carolina

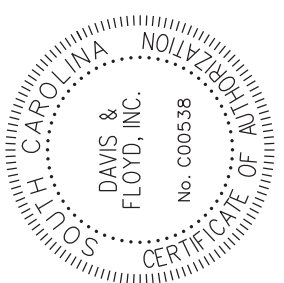
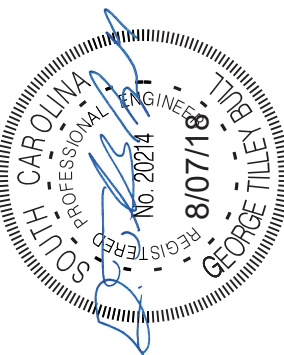

DGN: LEK
 RW: R/W:
 CHK: GTB

REVISION	DATE	BY
#		

DAVIS & FLOYD
 SINCE 1954

WWW.DAVISFLOYD.COM

3129 W. MONTAGUE AVENUE
 CHARLESTON, SC 29405
 (803) 799-2948

This drawing copy may have been reproduced at a size different than the original drawing. No responsibility is assumed for the use of incorrect scale. Drawings are not to be scaled.



NTS

SHEET NUMBER
5

FED. RD. DIV. NO.	STATE	COUNTY	PROJECT NO.	ROUTE NO.	SHEET NO.	TOTAL SHEETS
3	S.C.	COLLETON	31588.00	SC 63	5A	

SOUTH JEFFERIES BLVD

CONTROL POINTS

	NORTH	EAST	OFF.	STA.
CP1	389990.8390	2102210.4260	46.52' LT	73+46.62
CP2	388689.5610	2102159.8430	43.58' RT	60+52.50
CP3	389712.0603	2102223.2574	35.28' RT	70+79.36
CP4	389503.0448	2102134.2065	36.95' LT	68+62.39
CP5	389308.0471	2102102.4490	55.46' LT	66+65.69
CP6	389375.3417	2101842.8604	319.01' LT	67+15.30
CP7	389287.2330	2102259.9137	103.05' RT	66+55.66
CP8	389276.0814	2102406.4394	249.99' RT	66+54.34
CP9	388974.1192	2102177.1564	41.63' RT	63+37.58
CP10	388189.9782	2101961.7531	36.80' RT	55+24.27
CP11	388019.9227	2101689.4793	39.49' LT	52+10.48
CP12	387893.3871	2101524.3824	43.67' LT	49+98.64

BENCH MARKS (NAVD 88)

- BM 1 SPIKE LP C-5901 21269 107, SOUTH JEFFERIES BLVD.
N = 388667.9650 E = 2102152.6193 Z = 72.82
STA. = 60+30.46 OFF. = 37.83' RT
- BM 2 SPIKE LP 634427, SOUTH JEFFERIES BLVD.
N = 389852.5021 E = 2102269.4188 Z = 77.32
STA. = 72+32.16 OFF. = 52.47' RT

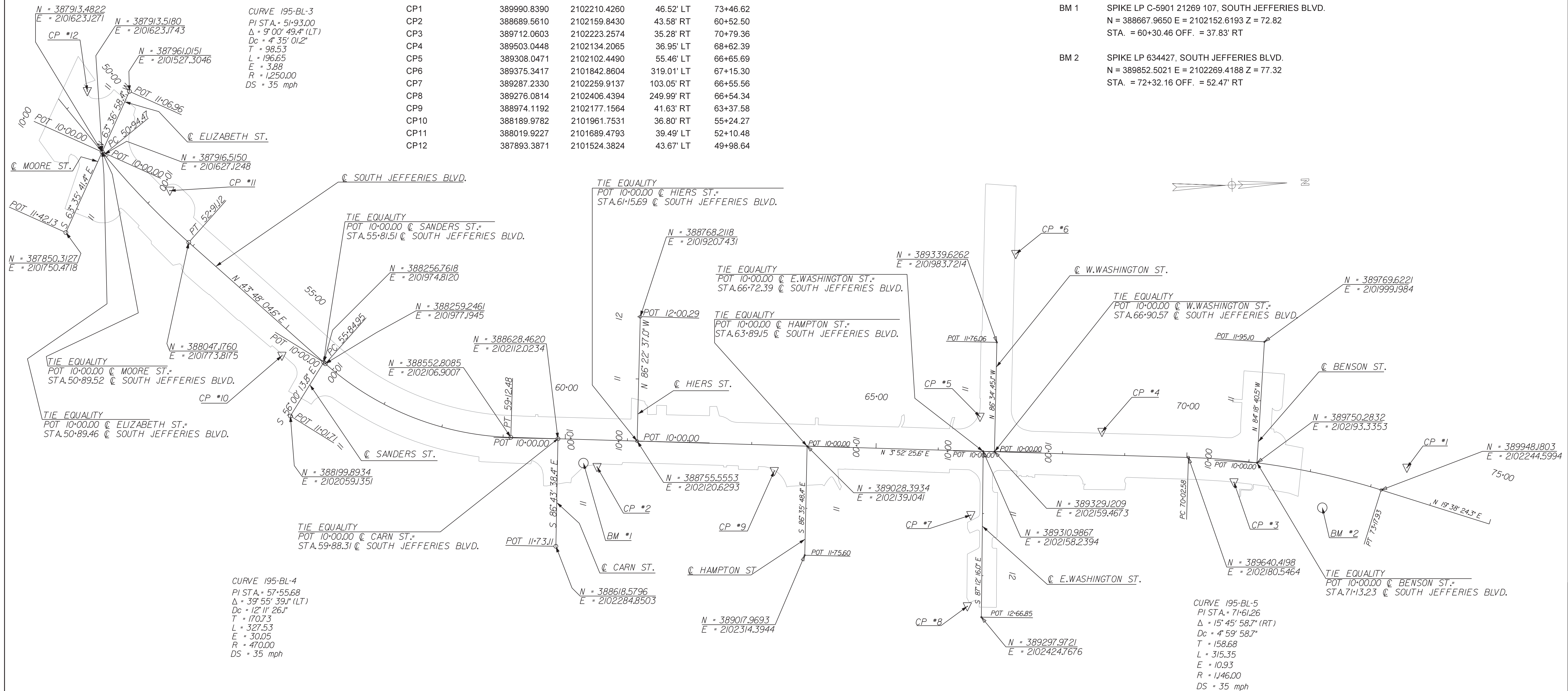

FILE NAME: \CHS-FS\data\Jobs\Even\31588-00\CV_dgn\in\ref-Phase 1E (B11)-locat\3158800-IB1-C05-A-reference-B.dgn



I-95 BUSINESS LOOP
PHASE 1E
REFERENCE SHEET

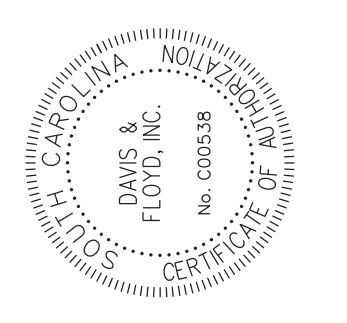
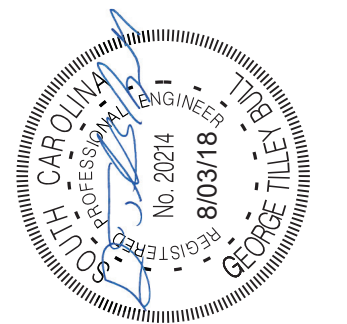

DGN: LEK
RW: GTB
CHK: GTB

REVISION	DATE	BY

DAVIS & FLOYD
SINCE 1954

3129 W. MONTAGUE AVENUE
COLUMBIA, SOUTH CAROLINA 29405
WWW.DAVISFLOYD.COM

This drawing copy may have been reproduced at a size different than the original drawing. No responsibility is assumed for the use of incorrect scale. Drawings are not to be scaled.

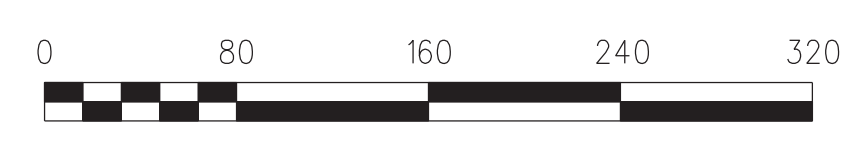

SCALE: 1"=80'

SHEET NUMBER
5A

FED. RD. DIV. NO.	STATE	COUNTY	PROJECT NO.	ROUTE NO.	SHEET NO.	TOTAL SHEETS
3	S.C.	COLLETON	31588.00	SC 63	6	

UTILITY	COMPANY
POWER	SCE&G
TELEPHONE	FRONTIER COMMUNICATIONS
TELEPHONE	PALMETTO RURAL TELEPHONE
SEWER	CITY OF WALTERBORO
WATER	CITY OF WALTERBORO
CABLE T.V.	COMCAST
CABLE T.V.	PALMETTO RURAL TELEPHONE

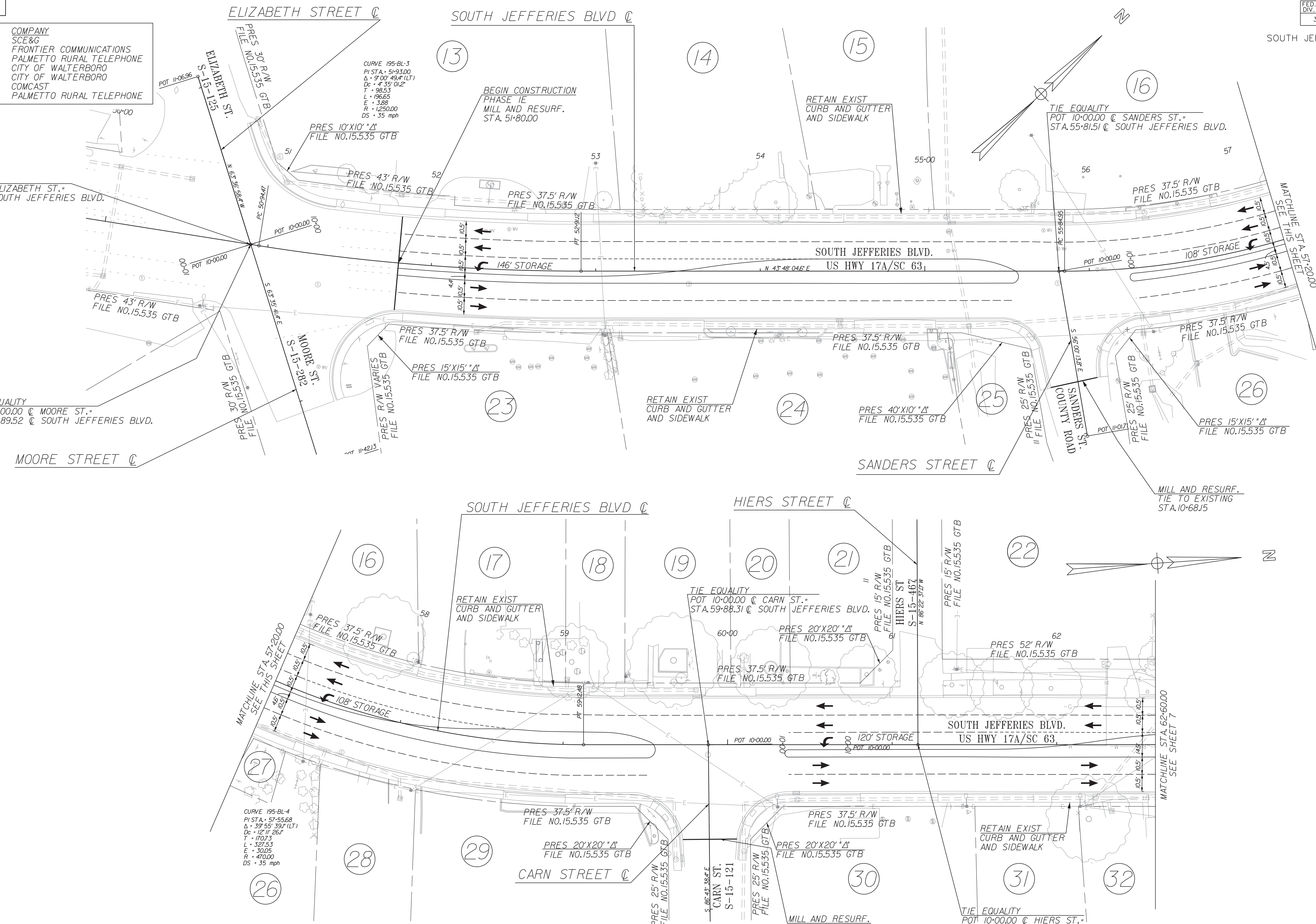

TIE EQUALITY
 POT 10+00.00 @ ELIZABETH ST.
 STA.50+89.46 @ SOUTH JEFFERIES BLVD.

TIE EQUALITY
 POT 10+00.00 @ MOORE ST.
 STA.50+89.52 @ SOUTH JEFFERIES BLVD.

TIE EQUALITY
 POT 10+00.00 @ SANDERS ST.
 STA.55+81.51 @ SOUTH JEFFERIES BLVD.

MILL AND RESURF.
 TIE TO EXISTING
 STA.10+68.15

TIE EQUALITY
 POT 10+00.00 @ CARN ST.
 STA.59+88.31 @ SOUTH JEFFERIES BLVD.

TIE EQUALITY
 POT 10+00.00 @ HIERS ST.
 STA.61+15.69 @ SOUTH JEFFERIES BLVD.

- NOTES:
1. ALL EXIST. DRAINAGE FEATURES TO REMAIN IN PLACE AND BE MAINTAINED BY CONTRACTOR.
 2. REPLACE EXISTING PAVEMENT MARKINGS.
 3. REPLACE EXISTING LOOP DETECTION AT TRAFFIC SIGNALS.

DAVIS & FLOYD
 SINCE 1954

This drawing copy may have been reproduced at a size different than the original drawing. No responsibility is assumed for the use of incorrect scale. Drawings are not to be scaled.

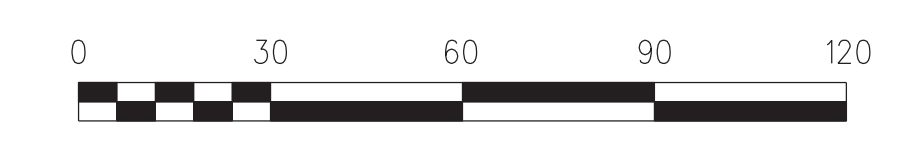

SCALE: 1"=30'



PREPARED FOR:
**I-95 BUSINESS LOOP
 PHASE 1E
 PLAN SHEET**
 Walterboro, South Carolina

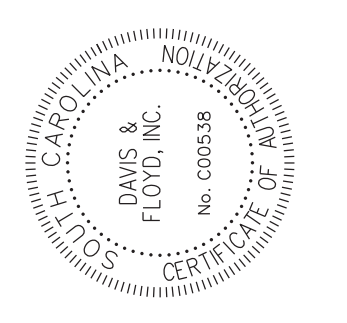
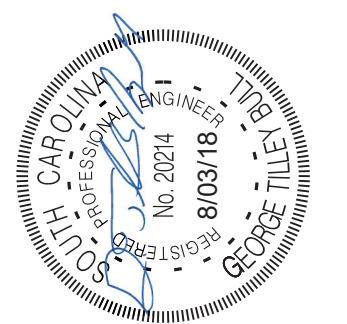

DGN: LEK
 R/W:
 CHK: GTB

REVISION	DATE	BY

SHEET NUMBER
6

PLOTTED: 8/3/2018 12:17:00 PM FILE NAME: \CHS\F\SD\Auto\Jobs\Even\31588-000\Cf_dgm\plan\sh-Phase 1E (1)11-locat_3158800-1B11-6-sh.dgn

FED. RD. DIV. NO.	STATE	COUNTY	PROJECT NO.	ROUTE NO.	SHEET NO.	TOTAL SHEETS
3	S.C.	COLLETON	31588.00	SC 63	7	

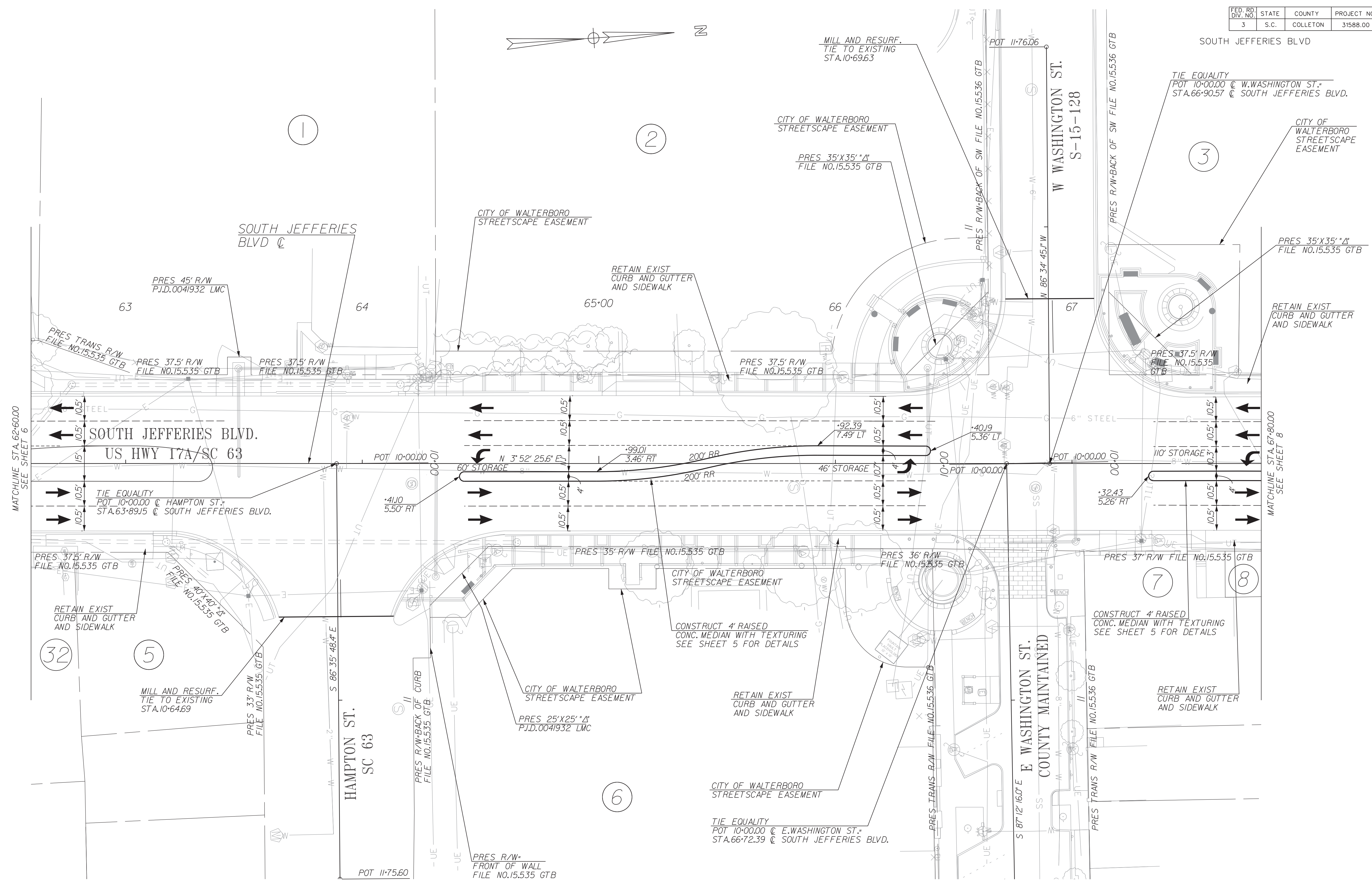
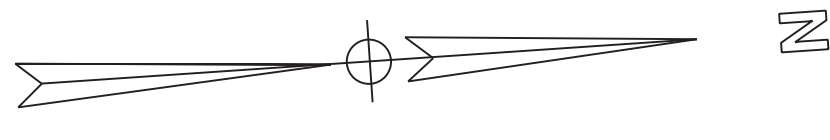

NOTES:
 1. ALL EXIST. DRAINAGE FEATURES TO REMAIN IN PLACE AND BE MAINTAINED BY CONTRACTOR.
 2. REPLACE EXISTING LOOP DETECTION AT TRAFFIC SIGNALS.

DAVIS & FLOYD
 SINCE 1954

3229 W. MONTAGUE AVENUE
 CHARLESTON, S.C. 29405
 WWW.DAVISFLOYD.COM

This drawing copy may have been reproduced at a size different than the original drawing. No responsibility is assumed for the use of incorrect scale. Drawings are not to be scaled.

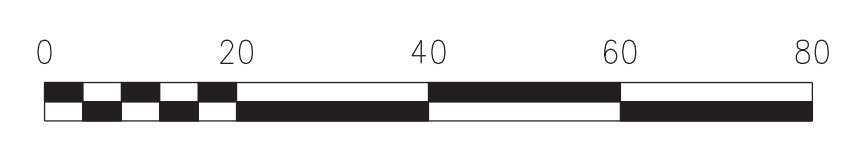

SCALE: 1"=20'



PREPARED FOR:
I-95 BUSINESS LOOP PHASE 1E PLAN SHEET
 Walterboro, South Carolina

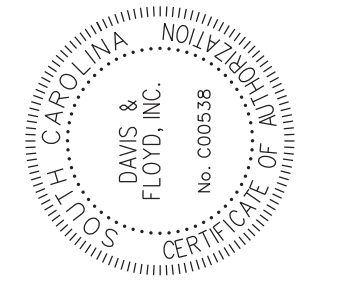
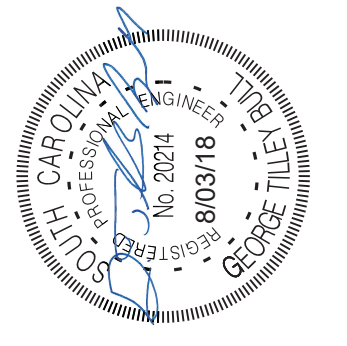

DGN: LEK
 R/W:
 CHK: GTB

REVISION #	DATE	BY

SHEET NUMBER
7

PLOTTED: 8/3/2018 12:17:03 PM FILE NAME: \CHS-F\SDATA\Jobs\Even\31588-00\CV_dgn\p1e01t-Phase 1E (B11)-locat_3158800-1B11-7-sht.dgn

FED. RD. DIV. NO.	STATE	COUNTY	PROJECT NO.	ROUTE NO.	SHEET NO.	TOTAL SHEETS
3	S.C.	COLLETON	31588.00	SC 63	8	

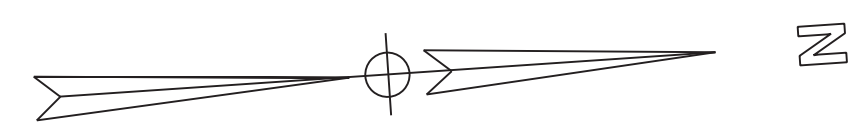

SOUTH JEFFERIES BLVD

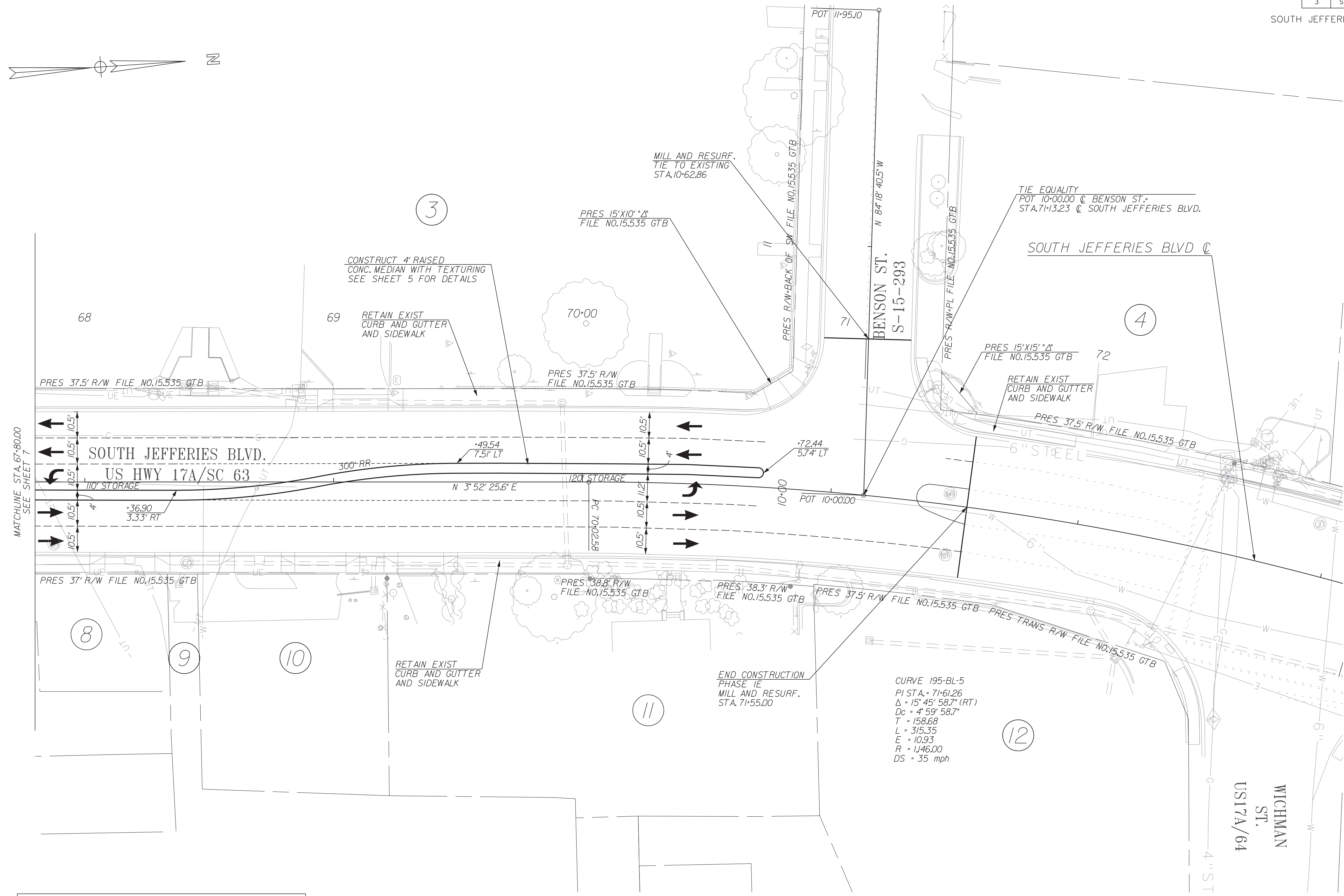

NOTES:
 1. ALL EXIST. DRAINAGE FEATURES TO REMAIN IN PLACE AND BE MAINTAINED BY CONTRACTOR.
 2. REPLACE EXISTING LOOP DETECTION AT TRAFFIC SIGNALS.

DAVIS & FLOYD
 SINCE 1954

3229 W. MONTAGUE AVENUE
 CHARLESTON, SC 29405
 (803) 799-2848
 WWW.DAVISFLOYD.COM

This drawing copy may have been reproduced at a size different than the original drawing. No responsibility is assumed for the use of incorrect scale. Drawings are not to be scaled.

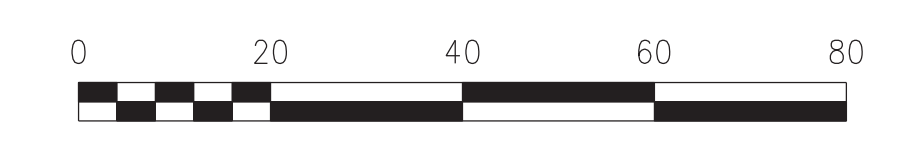

SCALE: 1"=20'



PREPARED FOR:
I-95 BUSINESS LOOP PHASE 1E PLAN SHEET
 Walterboro, South Carolina

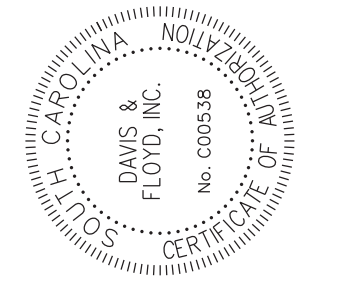
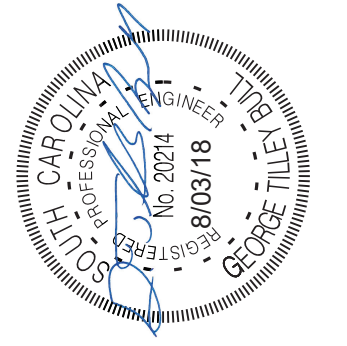

DGN: LEK
 R/W:
 CHK: GTB

REVISION #	DATE	BY

SHEET NUMBER
8

PLOTTED: 8/3/2018 12:17:06 PM FILE NAME: \CHS\FSD\Drawings\Even\31588-00\CF_dgn\plan\sh-Phase 1E (Blt)-local\3158800-IBlt-8-sh.dgn

FED. RD. DIV. NO.	STATE	COUNTY	PROJECT NO.	ROUTE NO.	SHEET NO.	TOTAL SHEETS
3	S.C.	COLLETON	31588.00	SC 63	PM01	

NOTE: INSTALL 4" RAISED PAVEMENT MARKERS PER SCDOT STANDARD DRAWINGS 630-105-00, 630-205-00, 630-210-00 AND 630-215-00.

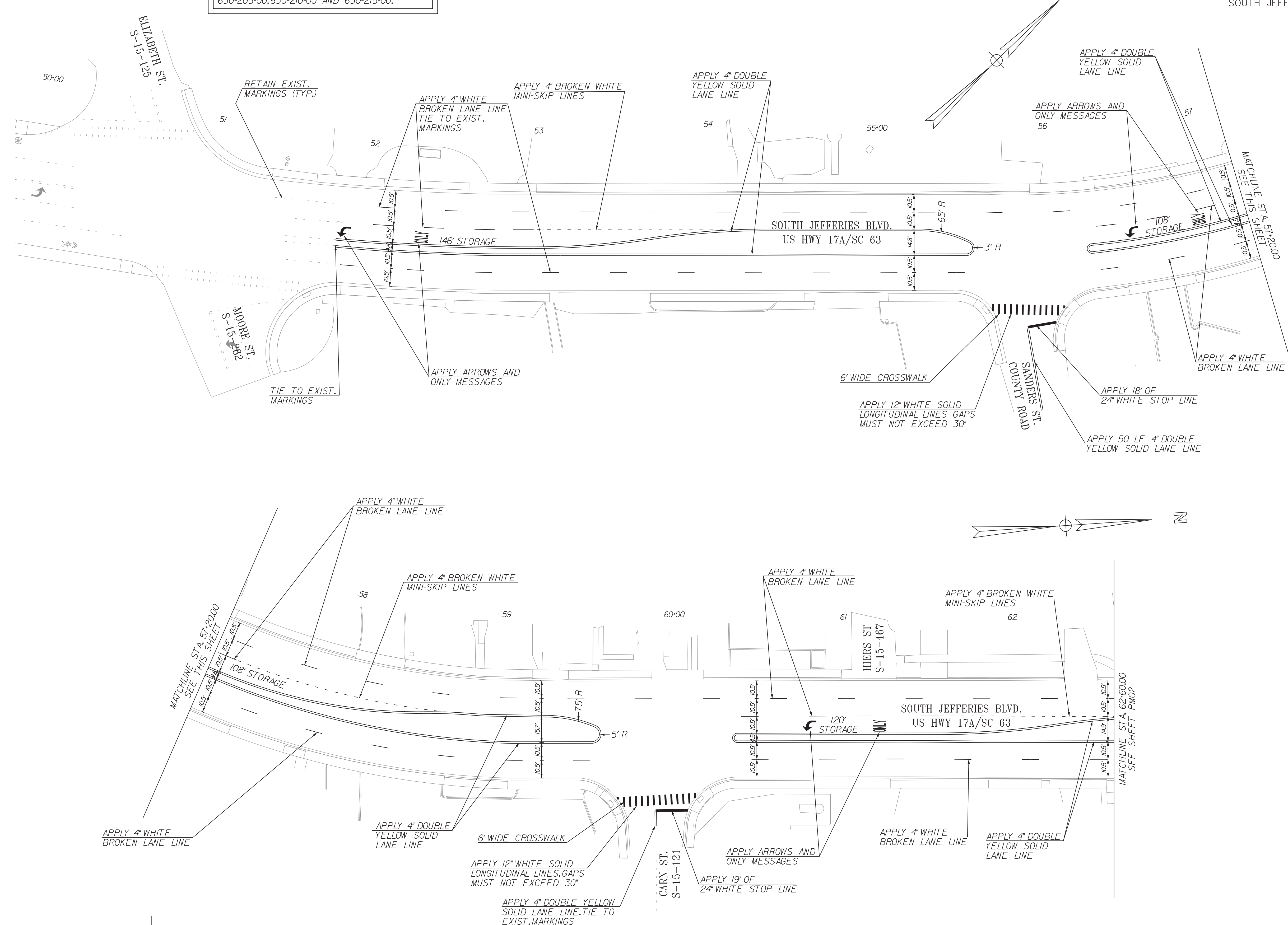

NOTES:
1. RETAIN EXISTING SIGNS UNLESS OTHERWISE SPECIFIED ON PLANS.

DAVIS & FLOYD
SINCE 1954

3229 W. MONTAGUE AVENUE
COLUMBIA, SC 29815
803-733-2900

This drawing copy may have been reproduced at a size different than the original drawing. No responsibility is assumed for the use of incorrect scale. Drawings are not to be scaled.

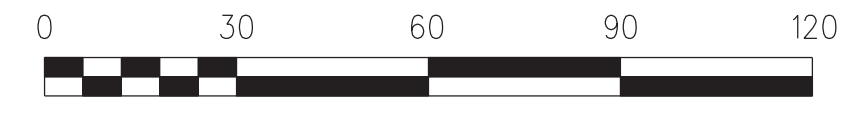

SCALE: 1" = 30'



PREPARED FOR:
**I-95 BUSINESS LOOP
PHASE 1E
PAVEMENT MARKINGS SHEET**
Walterboro, South Carolina

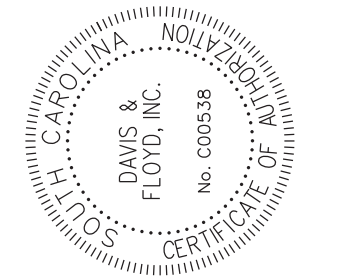

DGN: LEK
RW: [blank]
CHK: GTB

REVISION	DATE	BY
#		

SHEET NUMBER
PM01

12/7/09 PM FILE NAME: \CHS\FSD\Drawings\Even\31588-00\Cf_dgm\pavmark-Phase 1E (BIT)-local\3158800-IBIT-PM01.dgn PLOTTED: 8/3/2018

FED. RD. DIV. NO.	STATE	COUNTY	PROJECT NO.	ROUTE NO.	SHEET NO.	TOTAL SHEETS
3	S.C.	COLLETON	31588.00	SC 63	PM02	

NOTE: INSTALL 4" RAISED PAVEMENT MARKERS PER SCDOT STANDARD DRAWINGS 630-105-00, 630-205-00, 630-210-00 AND 630-215-00.

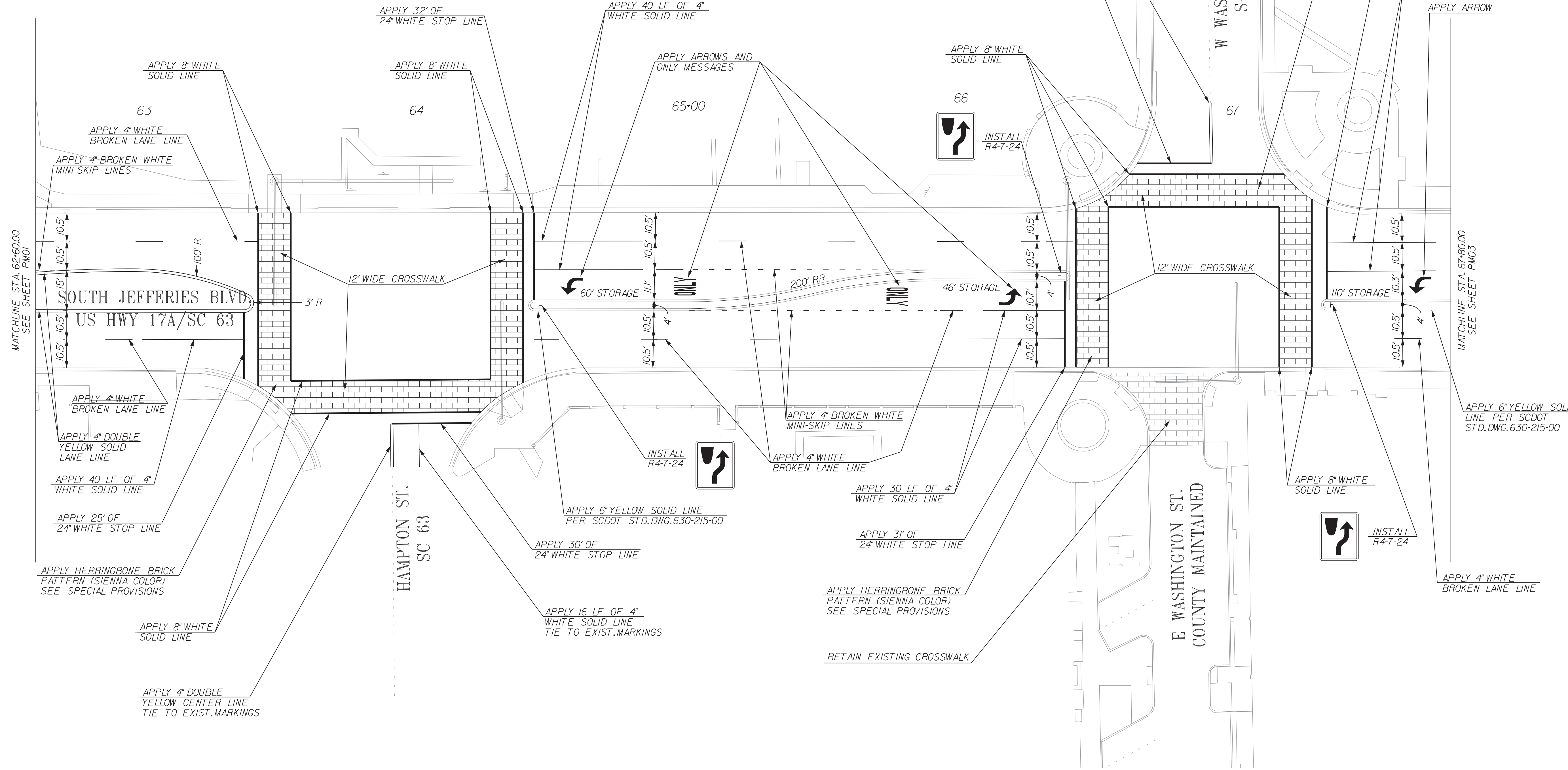
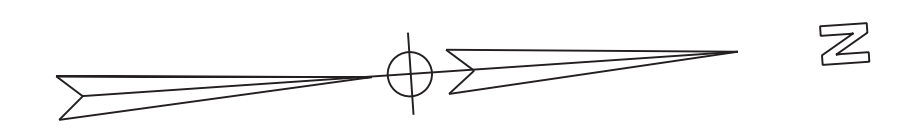

- NOTES:
1. RETAIN EXISTING SIGNS UNLESS OTHERWISE SPECIFIED ON PLANS.
 2. COORDINATE R4-7 SIGN INSTALLATIONS WITH MEDIAN CONCRETE PLACEMENT.
 3. SEE SCDOT STANDARD DRAWING SECTION 650 FOR SIGN INSTALLATION DETAILS.

DAVIS & FLOYD
SINCE 1954

3229 W. MONTAGUE AVENUE
COLUMBIA, SC 29205
803-733-2900

This drawing copy may have been reproduced at a size different than the original drawing. No responsibility is assumed for the use of incorrect scale. Drawings are not to be scaled.

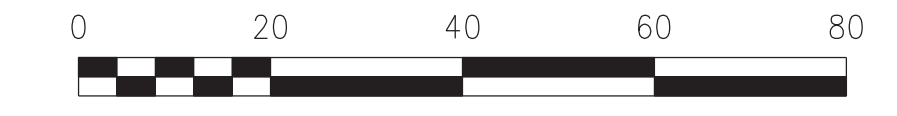

SCALE: 1"=20'

PREPARED FOR:
CITY OF WALTERBORO
152 WASHINGTON STREET
WALTERBORO, SOUTH CAROLINA 29488

I-95 BUSINESS LOOP PHASE 1E PAVEMENT MARKINGS SHEET
Walterboro, South Carolina

DGN: LEK
R/W: CHK: GTB

REVISION	DATE	BY

SHEET NUMBER
PM02

FILE NAME: \CHS\F\SD\Drawings\Even\31588-00\Cv_dgn\pavmark-Phase 1E (IBIT)-locat_3158800-IBIT-PM02.dgn
 12/7/11 PM
 PLOTTED: 8/3/2018

FED. RD. DIV. NO.	STATE	COUNTY	PROJECT NO.	ROUTE NO.	SHEET NO.	TOTAL SHEETS
3	S.C.	COLLETON	31588.00	SC 63	PM03	

SOUTH JEFFERIES BLVD

NOTE: INSTALL 4" RAISED PAVEMENT MARKERS PER SCDOT STANDARD DRAWINGS 630-105-00, 630-205-00, 630-210-00 AND 630-215-00.

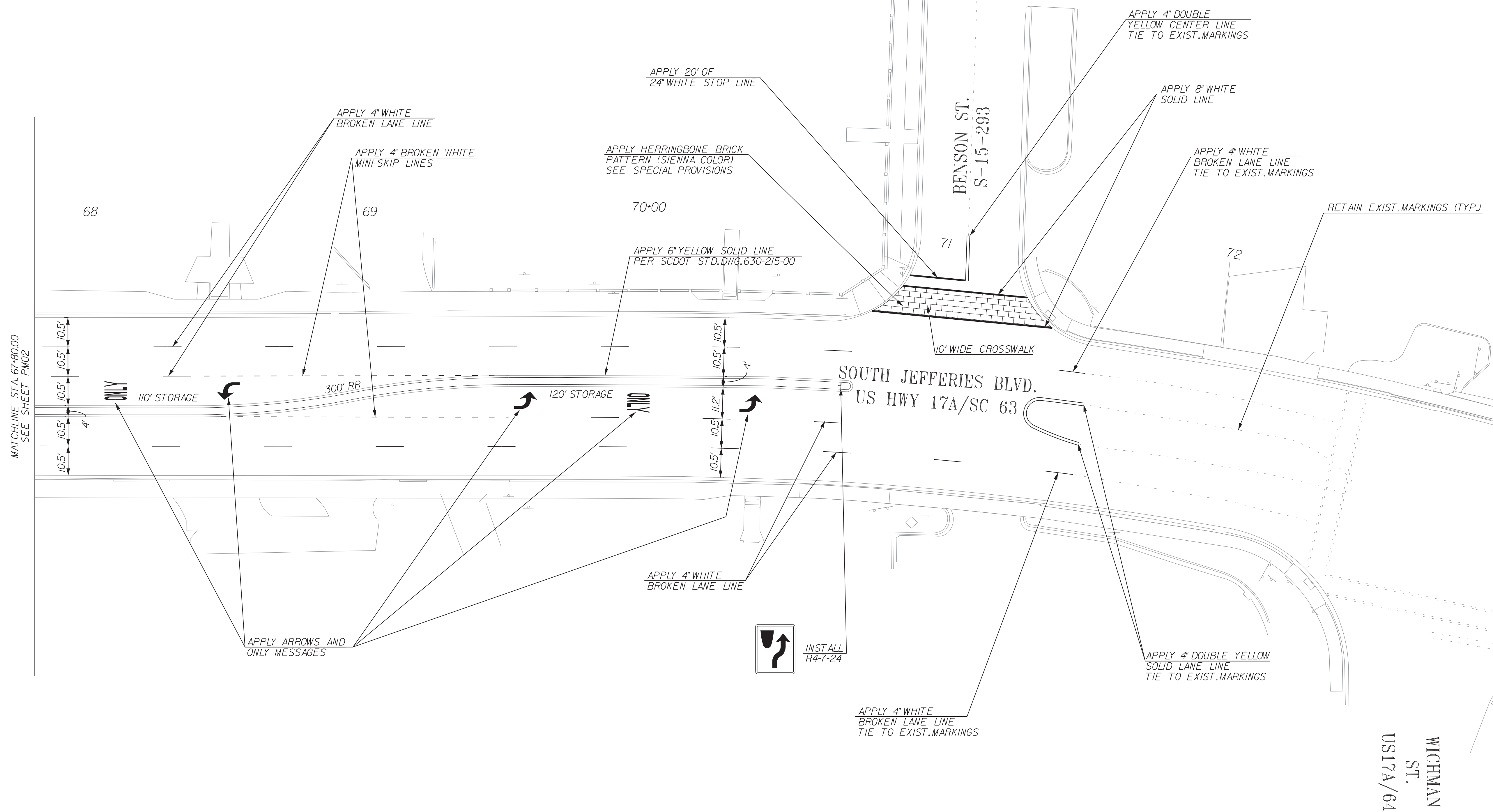
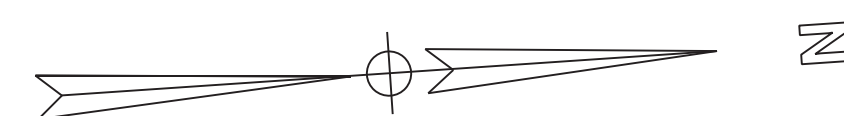

- NOTES:
1. RETAIN EXISTING SIGNS UNLESS OTHERWISE SPECIFIED ON PLANS.
 2. COORDINATE R4-7 SIGN INSTALLATIONS WITH MEDIAN CONCRETE PLACEMENT.
 3. SEE SCDOT STANDARD DRAWING SECTION 650 FOR SIGN INSTALLATION DETAILS.

DAVIS & FLOYD
SINCE 1954

3229 W. MONTAGUE AVENUE
COLUMBIA, SC 29405
(803) 734-2400

This drawing copy may have been reproduced at a size different than the original drawing. No responsibility is assumed for the use of incorrect scale. Drawings are not to be scaled.



SCALE: 1"=20'

PREPARED FOR:



CITY OF WALTERBORO
102 W. WALTON STREET
WALTERBORO, SOUTH CAROLINA 29488

**I-95 BUSINESS LOOP
PHASE 1E
PAVEMENT MARKINGS SHEET**

Walterboro, South Carolina

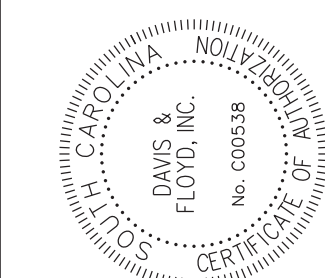

DGN: LEK
RAW:
CHK: GTB

REVISION	DATE	BY
#		

SHEET NUMBER
PM03

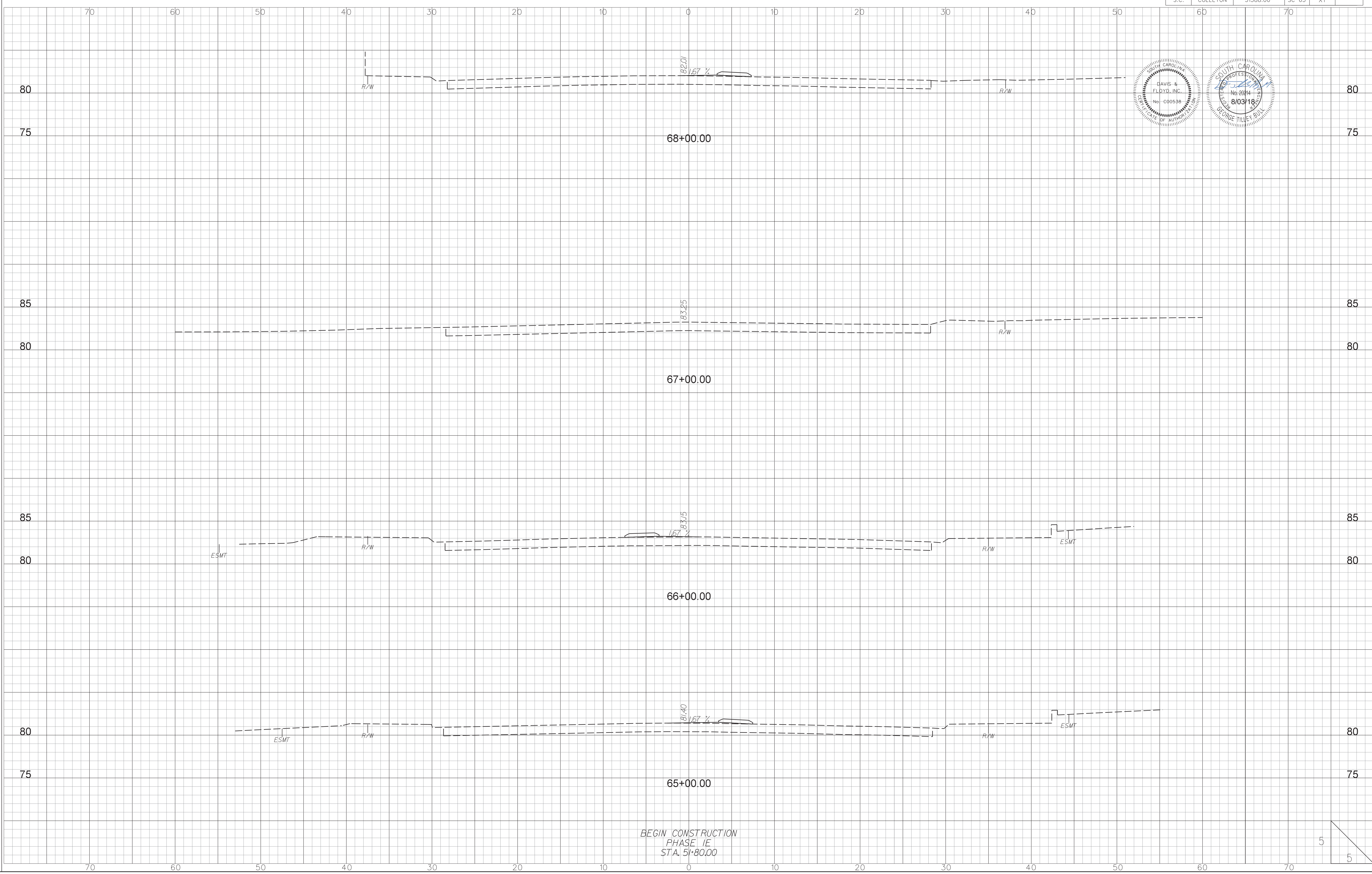
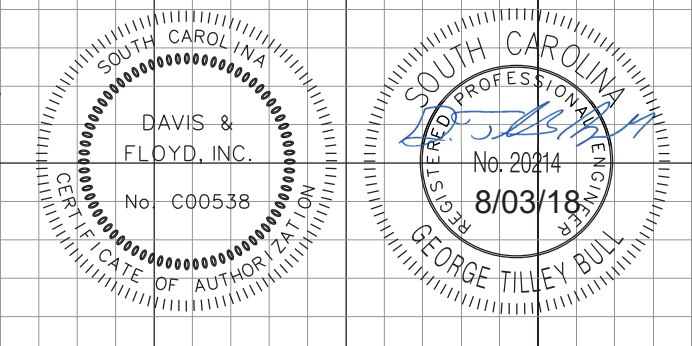

BEGIN CONSTRUCTION
PHASE 1E
STA. 51+80.00

5
5

PLOTTER: 8/31/2018 12:17:17 PM FILE NAME: \\CHS-FS1\Draw\Jobs\Even\31588-00\C\sc\3158800-PIX-IBIT.dgn

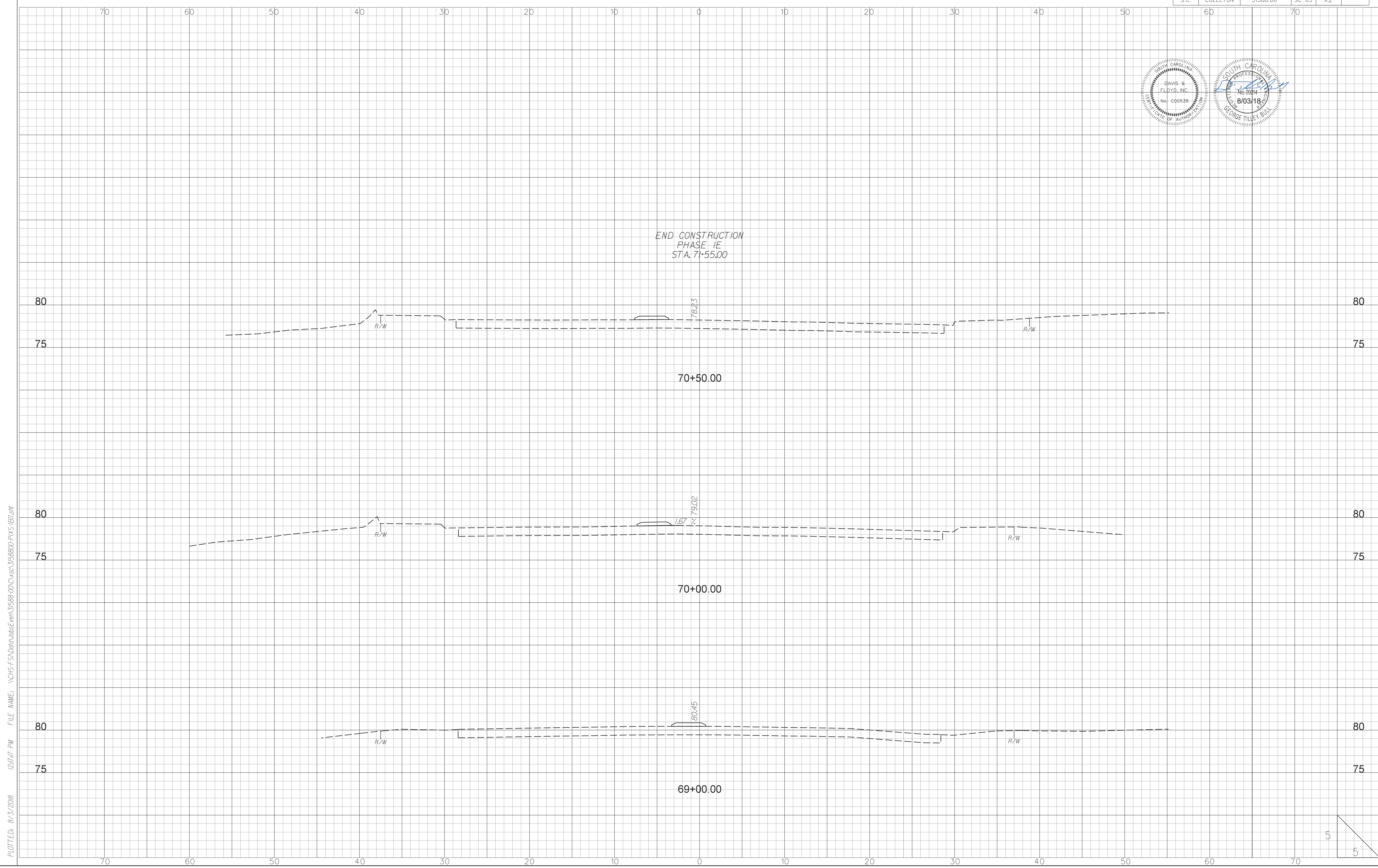
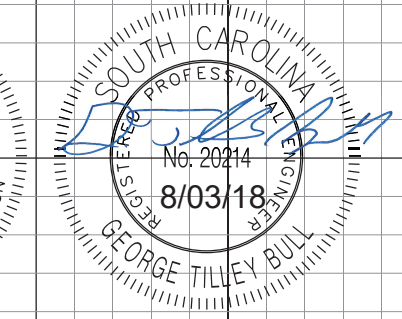
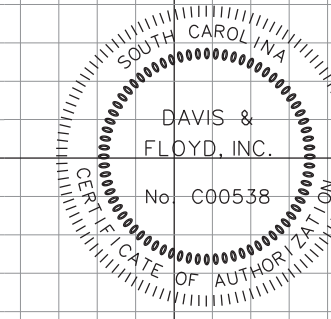

PLOTTED: 8/31/2018 12:47:17 PM FILE NAME: \\CHS-FS1\Draw\Jobs\Even\31588-00\C\sc\3158800-PM5-IB11.rvt

